

# Pegasus Table Assembly Instructions

## Step 1

Insert cable management strip (CM001) into the inner cavity of the cast leg (LE101)

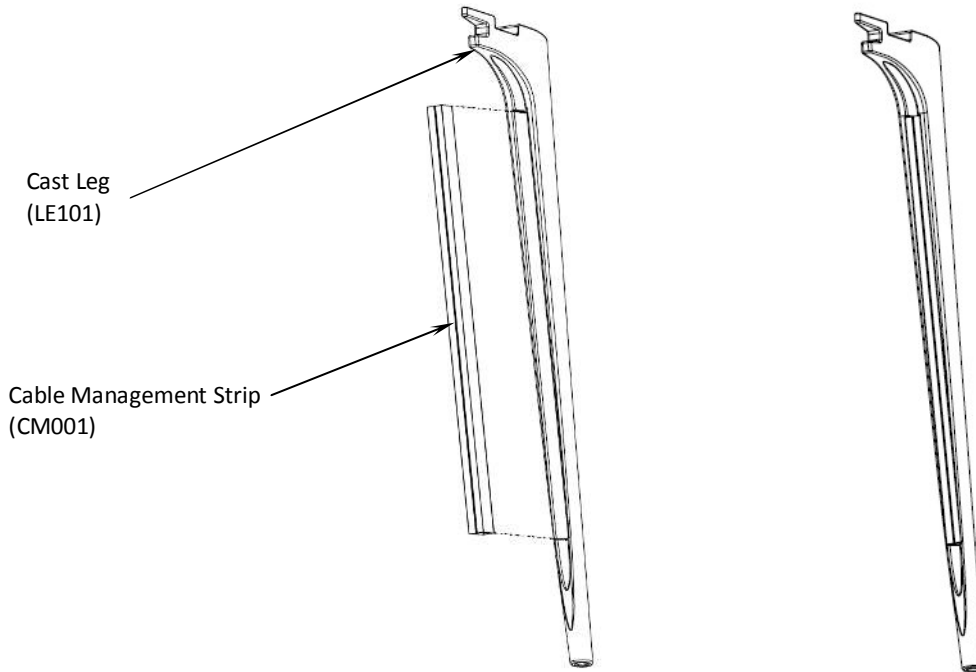

## Step 2

Screw adjusting foot (FT101) into the threaded hole in the base of the Leg

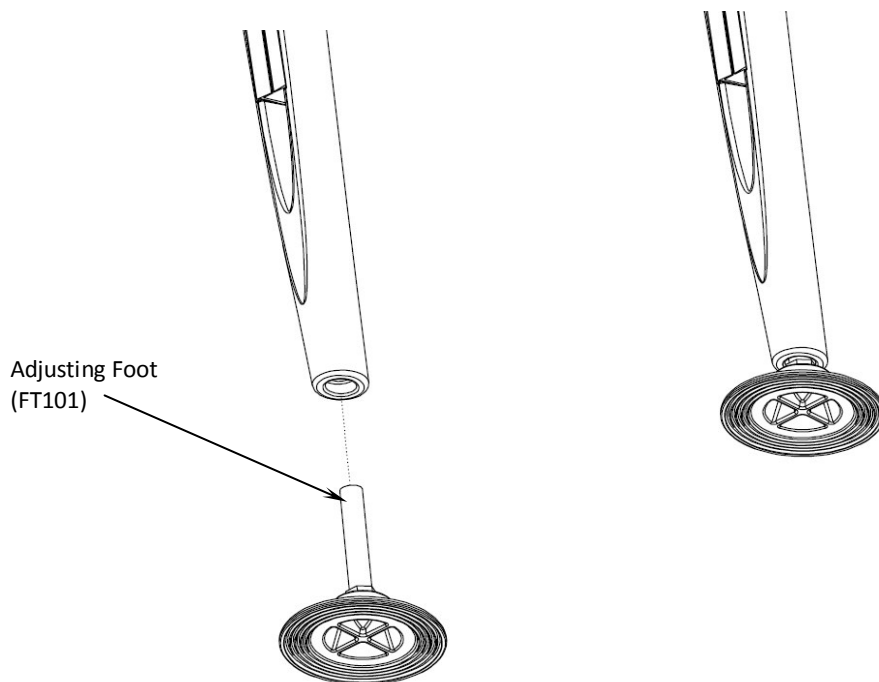

### Step 3

Fix corner brace (FI502) to the top of all three corner legs using three M6 x 20 countersunk socket head screws (SC012A)

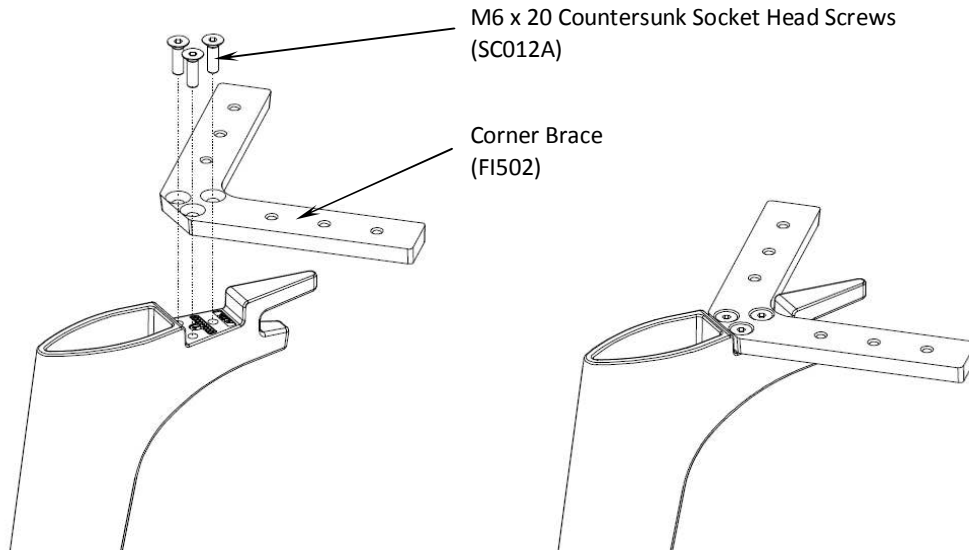

### Step 4

For tables with mid legs assemble straight brace (FI503) to leg using three M6 x 20 countersunk socket head screws (SC012A)

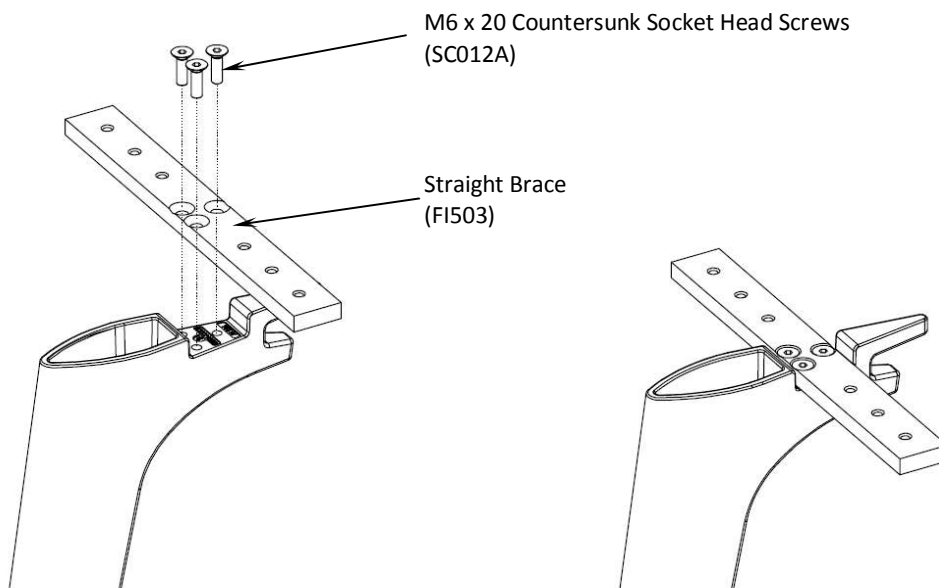

## Step 5

Insert cable management (CM002) into all support rails (SR001).

*Note - the length of the cable management strip should be approximately 115mm shorter than the overall length of the support rail into which it is inserted.*

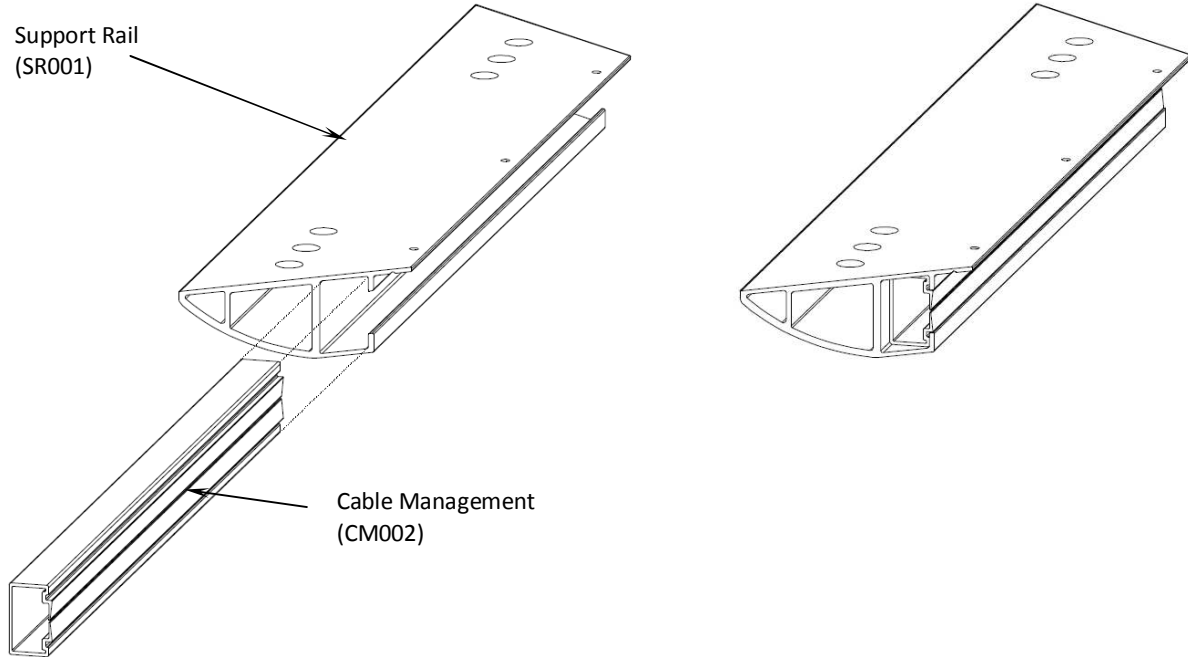

## Step 6 (only on tables with more than four legs)

Insert fixing block (FI505) into the end of the support rail (SR001, 002, or 003) after inserting the cable management rail.

*Note - it may be necessary to cut the cable management strip shorter to allow this*

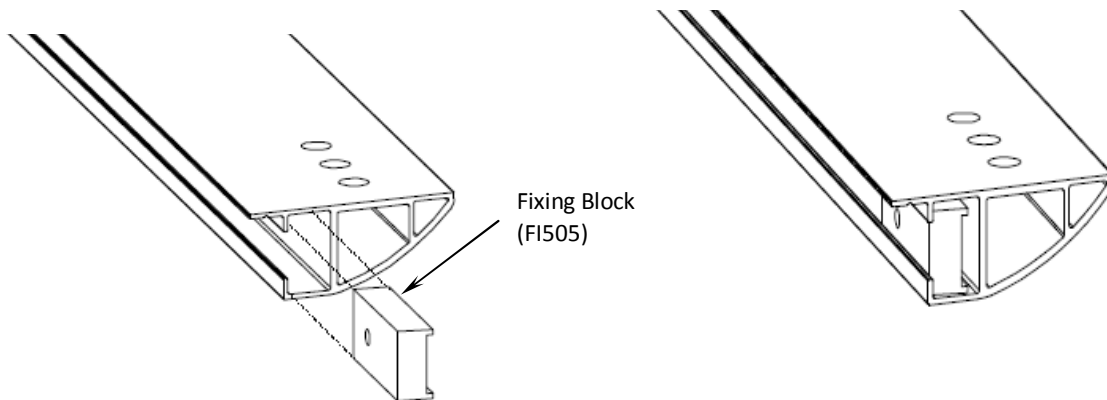

**Step 7** (only on tables with more than four legs)

Secure cross brace bracket (FI518 or FI519) to fixing block (FI505) using M6 x 25 flanged button head screw (SC311A) - **DO NOT FULLY TIGHTEN**

M6 x 25 Flanged  
Button Head Screw  
(SC311A)

Cross Brace Bracket  
(FI518 or FI519)

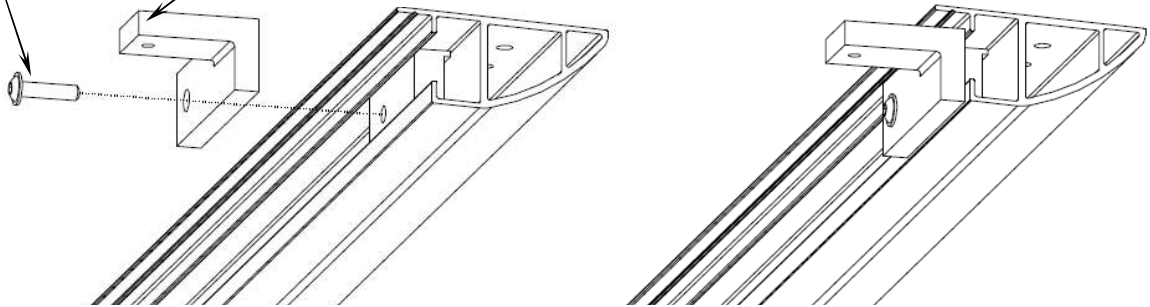

**Step 8** (only on tables with more than four legs)

Slide cross brace (SR006) to cross brace bracket (FI518 or FI519)

Cross Brace  
(SR006)

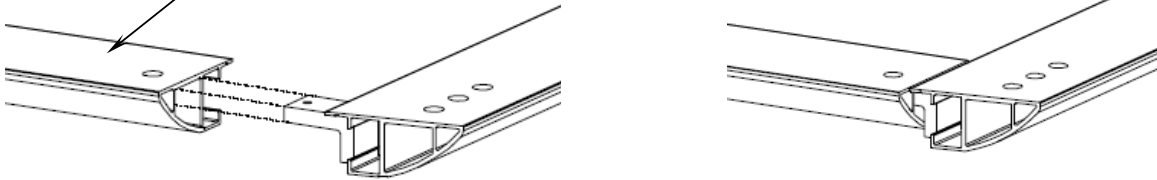

**Step 9** (only on tables with more than four legs)

Secure cross brace (SR006) with a M6 x 16 countersunk socket head screw (SC090A), set top of cross brace and support rail level and then tighten M6 x 25 flanged button head screw (as per step 7)

M6 x 16 Countersunk Socket Head Screw  
(SC090A)

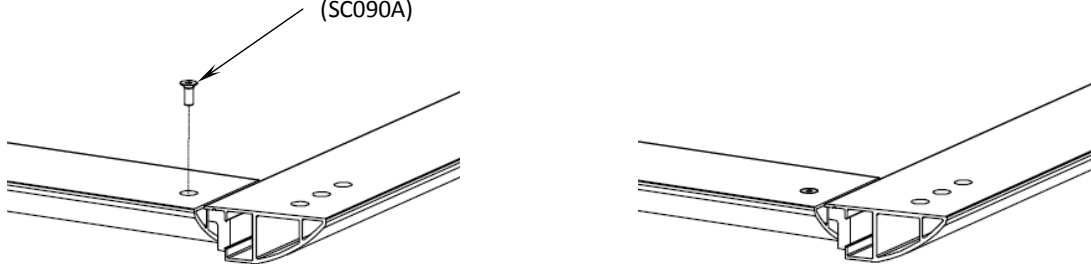

### Step 10

Slide support rails onto braces on each leg

*Note - refer to individual table drawings for plan of rails.*

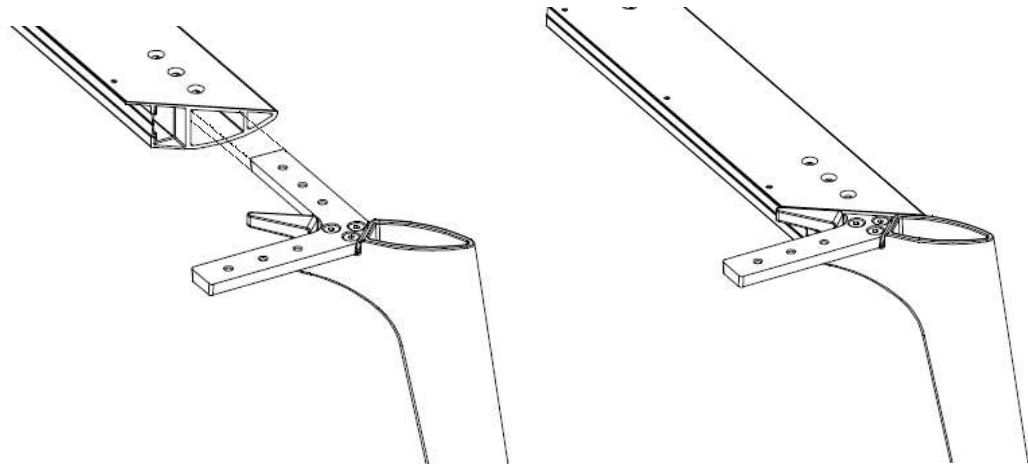

### Step 11

Fix support rail to brace using three M6 x 16 countersunk socket head screws (SC090A) at each end of rail

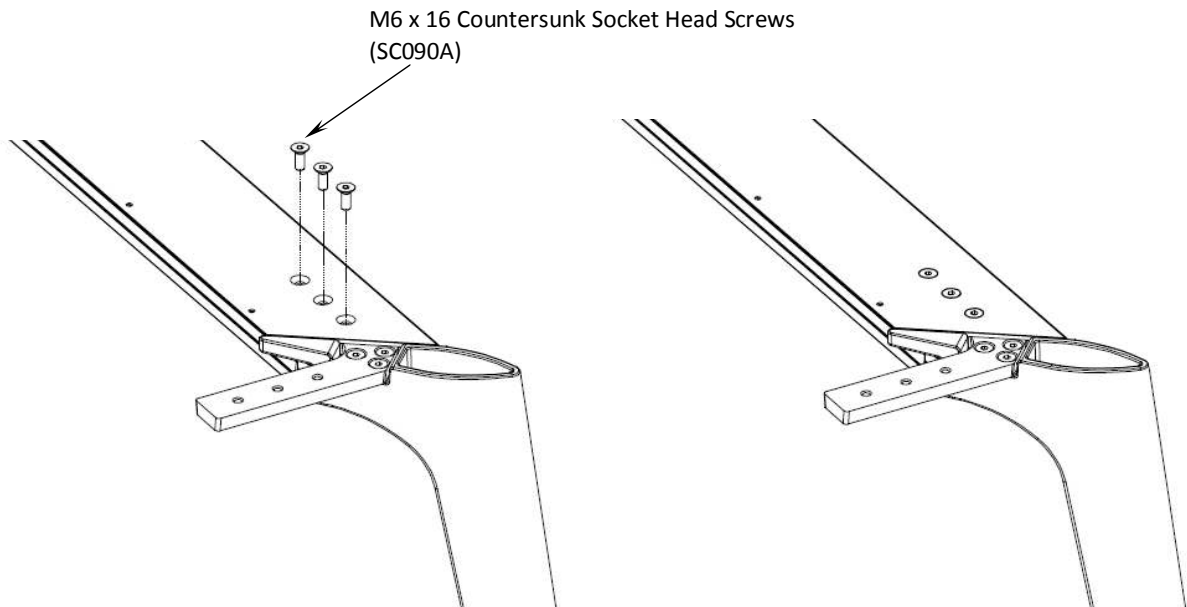

### Step 11

Fix table top to fully assembled frame using M6 x 16 flanged socket button head screw (SC304A)

